

IF MOUNTED OUTDOORS, IT SHOULD BE PLACED SO ROOF RUN-OFF WATER DOES NOT POUR DIRECTLY ON THE UNIT AND SHOULD BE UNRESTRICTED AT LEAST 12 INCHES FROM ALL SIDES.

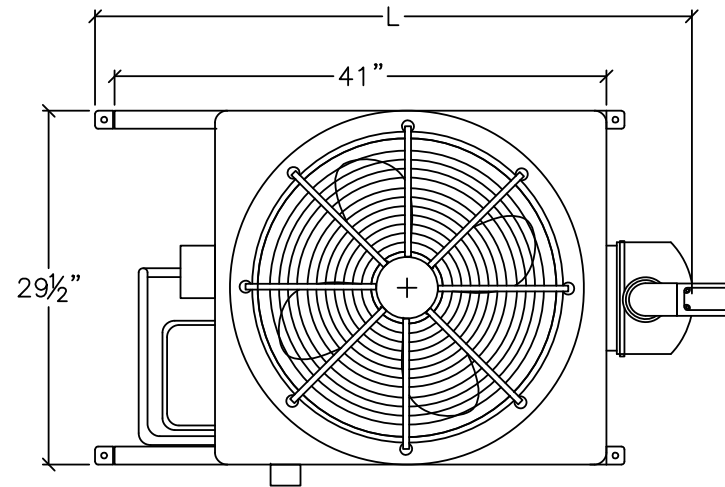

MULTI-TEMP WATER CHILLERS

MODEL	HP	NOMINAL BTUH/KW RATING	VOLTS/PHASE	AMPS. RLA/LRA	WATER MIN/MAX FLOW RATE (GPM)	H	L	AIR OUTLET (CFM)	AMBIENT AIR TEMPERATURE *MIN/MAX	SHIPPING WEIGHT (lbs.)
MT-1	2	24,000/7	208-240/1	9/58	20/40	53"	41"	1550	50/120 °F	365
MT-3	3	36,000/10.5	208-240/1	13.5/73	20/40	55"	41"	2175	50/120 °F	380
MT-4	3	36,000/10.5	208-240/3	11.3/74	20/40	55"	41"	2175	50/120 °F	380
MT-4-460	3	36,000/10.5	460/3	5.7/38	20/40	55"	41"	2175	50/120 °F	380
MT-5	4	48,000/14	208-240/1	18.6/93	30/60	61"	47"	2500	50/120 °F	450
MT-6	4	48,000/14	208-240/3	14.7/101	30/60	61"	47"	2500	50/120 °F	450
MT-6-460	4	48,000/14	460/3	6.5/51	30/60	61"	47"	2500	50/120 °F	450
MT-7	5	60,000/17.5	208-240/1	25/148	30/60	63"	55"	3700	50/120 °F	465
MT-8	5	60,000/17.5	208-240/3	19.7/139	30/60	63"	55"	3700	50/120 °F	465
MT-8-460	5	60,000/17.5	460/3	9.6/71	30/60	63"	55"	3700	50/120 °F	465

* WITH LOW AMBIENT CONTROLS UNIT WILL RUN DOWN TO 0°F

NOTE: ALL SINGLE PHASE UNITS HAVE A 13 SEER RATING. ALL THREE PHASE UNITS HAVE A 10 SEER RATING.

 Aqua Logic, Inc.
8268 Clairemont Mesa Blvd. Suite 302
San Diego, CA 92111

TITLE: MT-1 THRU MT-8
WATER CHILLER

LAST UPDATE: 1-19-07

DATE: 12-15-04

FILE: MT-1 thru 8 spec

BY CE